

# 120M

## Motor Grader

Joint Services



### Cat® C6.6 ACERT™ VHP Engine

Bass Power (1st gear) – Net	103 kW	138 hp
VHP Range – Net	103-114 kW	138-153 hp
VHP Plus Range – Net	103-129 kW	138-173 hp

### Weight

Total	17 726 kg	39,080 lb
Front Axle	5366 kg	11,830 lb
Rear Axle	12 360 kg	27,250 lb

### Moldboard

Blade Width	3.668 m	12 ft
-------------	---------	-------

## MISSION CAPABLE

### *The Cat® 120M – Tested, Proven, and Reliable – Mission Capable*

**The Cat 120M Motor Grader** is a highly productive machine. The 120M represents a revolution in operational efficiency, visibility, serviceability and overall productivity. It also provides unsurpassed operational readiness for the construction of airfields, roads, landing zones, defensive berms, anti-tank ditches, and other key military construction missions.

The 120M Motor Grader is air transportable on the C-130 in a drive-on, drive-off configuration.

#### **All Wheel Drive (AWD) System.**

The AWD system utilizes dedicated left and right pumps for precise hydraulic control. The Caterpillar exclusive Steering Compensation System enables a “powered turn” by adjusting the outside front tire speed up to 50% faster than the inside tire. The result is improved control, less damage to surfaces and a dramatic reduction of turning radius in poor underfoot conditions.

#### **AWD—Constant Net Power.**

When equipped with AWD, the 120M will automatically increase the gross power up to 26 kW (35 hp) when the system is engaged. This offsets the parasitic losses and maintains a constant net power to the ground for maximum productivity.

**AWD – Hydrostatic Mode.** Standard with AWD, this mode disengages the transmission and provides hydraulic power to the front wheels only. The ground speed is infinitely variable between 0-8 km/h (0-5 mph), perfect for precise finish work. This also allows an operator to drive a vehicle with transmission problems back to the shop for repairs.

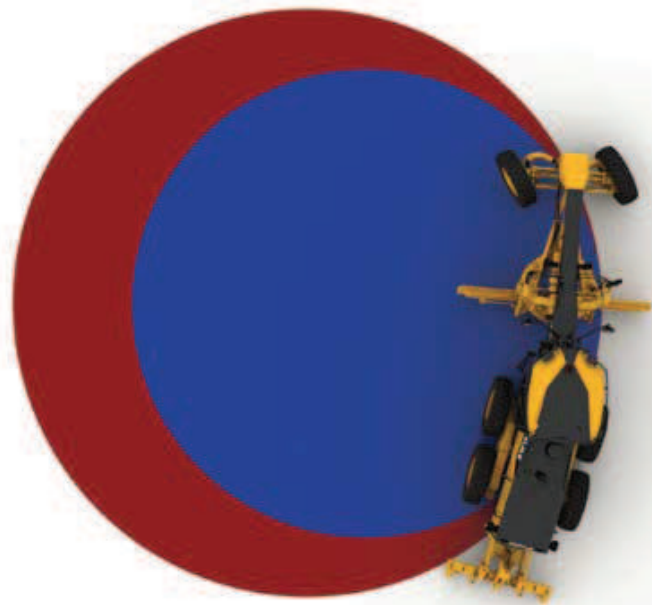

Without Steering Compensation

With Steering Compensation



**Performance.** The Cat C6.6 engine, with ACERT Technology, generates fewer emissions and optimizes fuel combustion. This engine also provides superior torque and lugging capability that can pull through sudden, short-term increases in loads, maintaining consistent, desirable grading speeds.

**Power Management.** The 120M Power Management System automatically delivers an additional five horsepower in each forward gear 1st through 4th, and each reverse gear 1st through 3rd. This standard feature optimizes rimpull for all gears by balancing traction, speed and horsepower while conserving fuel. The system limits horsepower in lower gears, which helps reduce wheel slip where traction is limited. With Variable Horsepower Plus (VHP Plus), an additional five-horsepower is delivered in each forward gear 5th through 8th for more power at higher speeds.

**Gear Selection.** Eight forward and six reverse gears give the operator a wide operating range, providing maximum productivity in all earthmoving applications.

**Hydraulic Demand Fan.** The hydraulic demand fan automatically adjusts cooling fan speed according to engine cooling requirements. This system reduces demands on the engine, putting more horsepower to the ground and improving fuel efficiency.

**Inching Pedal.** Allows precise control of machine movements in any gear with low pedal effort and excellent modulation, critical in close-quarter work or finish grading.

**Hydraulic Brakes.** The oil bathed, multi-disc service brakes are hydraulically actuated (1), providing smooth predictable braking. With brakes located at each tandem wheel (2), dependable stopping power is delivered each time. The parking brake is also integrated into the Operator Presence System to prevent unintended machine movement.

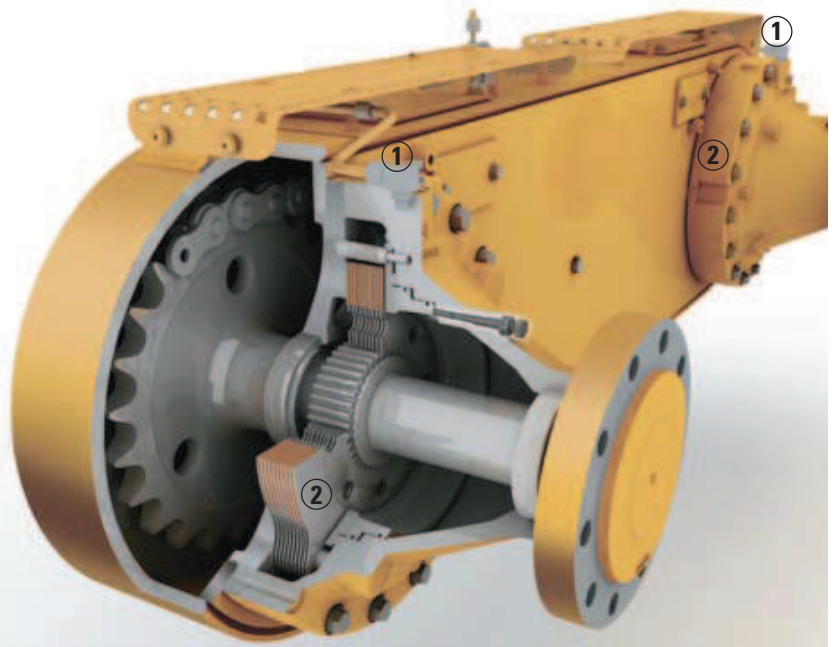

## MISSION CAPABLE

*The Cat® 120M – Tested, Proven, and Reliable – Mission Capable*

**Shimless Moldboard Retention System.** The unique shimless moldboard retention system reduces the potential for blade chatter, preventing a washboard effect when grading. Vertical and horizontal adjusting screws keep the moldboard's wear strips aligned for precise blade control and dramatic reductions in service time.

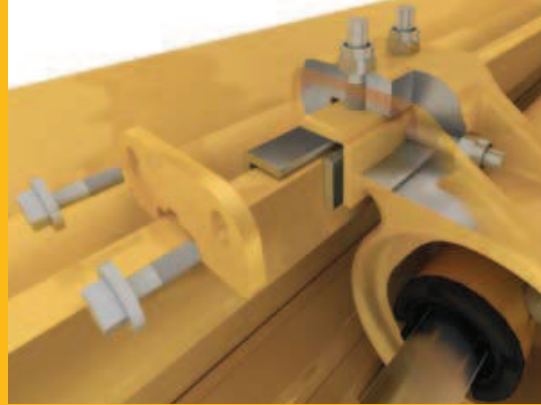

Shimless moldboard retention system with adjusting screws.

**Top-Adjust Drawbar Wear Strips.** The patented top-adjust wear strips dramatically reduce drawbar/circle adjustment time. By removing the access plates on top of the drawbar, shims and wear strips can easily be added or replaced. This feature reduces service downtime.



Top-adjust drawbar wear strips

**Replaceable Wear Inserts.** Durable nylon composite wear inserts reduce rotational friction for maximum circle torque and longer component life. They are located between the drawbar and circle, and between the support shoes and circle. High load-resistant brass wear strips are placed between the blade mounting group and moldboard. This sacrificial wear system can be replaced easily and helps keep components tight for fine grading.



Replaceable wear inserts.



**Left Joystick Functions.** The left joystick primarily controls the machine direction and speed.

1. Steering: Lean joystick left and right
2. Articulation: Twist joystick left and right
3. Articulation Return to Center: Yellow thumb button
4. Wheel Lean: Two black thumb buttons
5. Direction: Index trigger shifts transmission to forward, neutral or reverse
6. Gear Selection: Two yellow thumb buttons upshift and downshift
7. Left moldboard lift cylinder: Push joystick to lower, pull joystick to raise

Left moldboard lift cylinder float: Pushing joystick through detent engages float

**Right Joystick Functions.**

The right joystick primarily controls the Drawbar, Circle and moldboard functions.

1. Right moldboard lift cylinder: Push joystick to lower, pull joystick to raise  
  
Right moldboard lift cylinder float: Pushing joystick through detent engages float
2. Moldboard slide: Lean joystick left and right
3. Circle turn: Twist joystick left and right
4. Moldboard tip: Thumb switch fore and aft
5. Drawbar center shift: Thumb switch left and right
6. Electronic Throttle Control: Trigger switch is resume and decrement
7. Differential Lock/Unlock: Yellow button

**Articulation Return-to-Center.** This exclusive feature automatically returns the machine to a straight frame position from any articulation angle with the touch of a single button. Return-to-Center helps improve productivity and safety by allowing the operator to focus on controlling the moldboard.

**Advanced Electro-Hydraulic System.** The 120M incorporates a state-of-the-art electro-hydraulic system. Advanced joystick controls provide unmatched controllability with precise, predictable hydraulic movements.

**Circle Drive Slip Clutch.** This standard feature protects the drawbar, circle and moldboard from shock loads when the blade encounters an immovable object. It also reduces the possibility of abrupt directional changes in poor traction conditions, protecting the machine, operator and surroundings.



**Scarifier Control Pod.** The scarifier control is ergonomically positioned to allow simple, comfortable operation of the mid-mount scarifier.

## OPERATOR SAFETY/COMFORT

*The Cat® 120M – Tested, Proven, and Reliable – Mission Capable*



**Crew Protection Kit.** The armored crew protection kit (CPK) on the 120M was developed with the Troops's protection and survivability in mind. The armored cab provides the operator with 360° protection, including the roof and the floor, from small arms and fragmentation threats. An emergency egress hatch is provided thru the roof and is accessible from both the inside by the operator and from the outside by rescue personnel. The transparent armor provides excellent operator visibility of the machine and surrounding work area. These features of the CPK allow the soldier to complete military tasks safely and effectively.



**Visibility.** The 120M boasts excellent visibility to the work area, made possible with angled cab doors and replacement of all levers and the steering wheel with two electro-hydraulic joystick controls.

**Low Interior Sound and Vibration Levels.** Isolation mounts for the cab, engine and transmission, in addition to the location of the hydraulic pump and valves, provide significant sound and vibration reductions.

**HVAC.** The heating, ventilation and air conditioning system uses intelligent vent placement for consistent climate control and clear windows for every condition. The high capacity system dehumidifies air and pressurizes the cab, circulating fresh air and sealing out dust. An easily accessible fresh air filter is located outside the cab at ground level for quick replacement or cleaning.



**Operator Presence System.** The Operator Presence System keeps the parking brake engaged and hydraulic implements disabled until the operator is seated and the machine is ready for safe operation.

**Secondary Steering System.** The standard secondary steering system automatically engages an electric hydraulic pump in case of a drop in steering pressure, allowing the operator to steer the machine to a stop.

**Electrical Disconnect Switch.** A battery disconnect switch, located inside the left rear enclosure, provides ground level lockout of the electrical system to prevent inadvertent starting of the machine.

**Hydraulic Lockout.** A simple switch located in the cab disables all implement functions while still providing machine steering control. This safety feature is especially useful while the machine is loading.

## SERVICEABILITY

*The Cat® 120M – Tested, Proven, and Reliable – Mission Capable*



**Monitoring Systems.** The 120M Motor Grader maximizes on-board diagnostics capability using electronic control modules (ECMs) to monitor engine and machine systems. Cat Electronic Technician (ET) software accesses information from the ECMs allowing technicians to view status parameters, logged codes, active codes, perform functional tests, and record and view data logs of equipment operation. The instrument panel conveniently displays fault or event codes, while the Messenger system (mounted inside the cab) provides text related to the fault code. This diagnostic capability allows Army Units to maintain Motor Grader readiness while minimizing the maintenance burden.



**Maintenance.** Proper maintenance of your motor grader can help control expenses and lower your owning and operating costs. The 120M provides unmatched serviceability by offering:

- Hydraulic service center
- Electric service center
- Well-protected, easily visible sight gauges
- Ground level maintenance points
- Easy access to engine compartment
- Ecology drains for simple and clean fluid drainage
- Brake wear indicators for ease of inspection
- Maintenance-free batteries
- Military Sampling Valves



**Remanufactured Parts.** Cat engines and major components are designed to be remanufactured and provide multiple life cycles. The Cat Reman program is more extensive than most rebuild programs. Components are actually remanufactured in the factory to the original specifications with necessary product updates.





**Service Life Extension Program (SLEP).** The Service Life Extension Program (SLEP) is based on a highly successful program currently in place with the DoD for the modernization of the U.S. military's construction and material handling equipment. As a result, thousands of Cat machines are now realizing a second life. The SLEP process is performed at strategically selected dealers throughout the Caterpillar worldwide dealer network.

The SLEP efforts have proven to be a great value for the DoD, allowing the machines to meet mission requirements and realize an additional machine life cycle. The fact that this work can be done at the dealer sites saves the Government millions in shipping costs.

**Worldwide Locations.** The Caterpillar global network of authorized dealers supports the U.S. Military in every corner of the globe. With heavy construction equipment dealers located in over 200 countries, Caterpillar's support organization provides global coverage.



**Service Capabilities.** Cat field service technicians have the experience and tools necessary to service your motor grader on-site. Field service trucks are fully loaded with state-of-the-art tools and diagnostic equipment as well as specifications and schematics for every Cat machine. Technical experts at the dealership and at Caterpillar are available to provide assistance to field service technicians when needed. When on-site repair isn't enough, Cat dealerships are fully-equipped to service your motor grader quickly.

**Dealer Support.** The Caterpillar global network of authorized dealers is the best in the world at providing support to keep your equipment up and running. With 99.7% of parts shipped within 24 hrs, Cat dealers are partners in support to the motor grader.

## OPERATING SPECIFICATIONS

### Engine

Model	Cat® C6.6 ACERT™ VHP	
VHP Plus range – Net	103-129 kW	138-173 hp
Displacement	6.6 L	403 in <sup>3</sup>
Bore	105 mm	4.13 in
Stroke	125 mm	4.92 in
Torque rise (VHP Plus)	40%	
Max torque (VHP Plus)	859 N·m	690 lb ft
Speed @ rated power	2,000 rpm	
Number of cylinders	6	

- Net power is tested per ISO 9249, SAE J1349, and EEC 80/1269.
- Standards in effect at the time of manufacture.
- VHP Plus is standard on Military Machines with AWD.
- Max torque (VHP Plus) measured at 1,400 rpm.
- Net power advertised is the power available at rated speed of 2,000 rpm, measured at the flywheel when engine is equipped with fan running at minimum speed, air cleaner, muffler and alternator.

### 120M Net Power

Gear	VHP Plus kW (hp) – Net
Fwd. 1st	103 (138)
2nd	106 (143)
3rd	110 (148)
4th	114 (153)
5th	118 (158)
6th	121 (163)
7th	125 (168)
8th	129 (173)
Rev. 1st	103 (138)
2nd	106 (143)
3rd – 6th	110 (148)

### Power Train

Forward/Reverse Gears	8 Fwd/6 Rev
Transmission	Direct drive, power shift, countershaft
Brakes – Service	Multiple oil-disc
– Parking	Multiple oil disc
– Secondary	Dual circuit control system

### All-Wheel Drive System

Motor Type	2 Infinitely variable axial piston
Pump Type	2 Variable piston
Operational gears	Forward = 1-7 Reverse = 1-5

### Hydraulic System

Circuit type	Electro-hydraulic load sensing, closed center	
Pump type	Variable piston	
Pump output	151 L/min	40 gal/min
Maximum system pressure	24,100 kPa	3,500 psi
Standby Pressure	3100 kPa	450 psi

- Pump output measured at 2,150 rpm

## Operating Specifications

Top Speed – Fwd.	44.5 km/h	27.7 mph
– Rev.	37.8 km/h	23.5 mph
Turning radius, outside front tires	11.3 m	37 ft 1 in
Steering range – left/right	42°	
Articulation angle – left/right	20°	
Fwd. 1st	3.9 km/h	2.4 mph
2nd	5.3 km/h	3.3 mph
3rd	7.6 km/h	4.75 mph
4th	10.5 km/h	6.5 mph
5th	16.4 km/h	10.2 mph
6th	22.2 km/h	13.8 mph
7th	30.6 km/h	19 mph
8th	44.5 km/h	27.7 mph
Rev. 1st	3.3 km/h	2 mph
2nd	6.2 km/h	3.8 mph
3rd	8.9 km/h	5.6 mph
4th	13.9 km/h	8.6 mph
5th	26 km/h	16.1 mph
6th	37.8 km/h	23.5 mph

## Service Refill

Fuel Capacity	340 L	90 gal
Cooling system	40 L	10.4 gal
Hydraulic system – tank	60 L	15.9 gal
Engine Oil	15.5 L	4.1 gal
Trans./Diff./Final Drives	50 L	13.2 gal
Tandem housing (each)	61 L	16.9 gal
Front wheel spindle bearing housing	0.5 L	0.1 gal
Circle drive housing	7 L	1.8 gal

## Frame

Circle – diameter	1530 mm	60.2 in
– blade beam thickness	35 mm	1.4 in
Drawbar – height	152 mm	6 in
– width	76.2 mm	3 in
– thickness	9.5 mm	0.4 in
– yoke bar thickness	19.1 mm	0.75 in
Front frame structure		
– height	254 mm	10 in
– width	254 mm	10 in
– thickness	16 mm	0.6 in
Front axle		
– height to center	572 mm	22.5 in
– wheel lean, left/right	18°	
– total oscillation per side	32°	

## Tandems

Height	502 mm	19.76 in
Width	171.7 mm	6.76 in
Sidewall thickness – inner	14 mm	0.5 in
– outer	16 mm	0.6 in
Drive chain pitch	44.5 mm	1.8 in
Wheel axle spacing	1510 mm	59.5 in
Tandem oscillation – front up	15°	
– front down	25°	

## Moldboard

Blade width	3.668 m	12 ft
Moldboard – height	610 mm	24 in
– thickness	22 mm	0.87 in
Arc radius	413 mm	16.3 in
Throat clearance	123.9 mm	4.9 in
Cutting edge – width	152.4 mm	6 in
– thickness	16 mm	0.6 in
End Bit – width	152.4 mm	6 in
– thickness	16 mm	0.6 in

## OPERATING SPECIFICATIONS

### Blade Range

Circle centershift – right	656 mm	25.8 in
– left	656 mm	25.8 in
Moldboard sideshift – right	660 mm	26 in
– left	510 mm	20.1 in
Maximum blade position angle	90°	
Blade tip range – forward	40°	
– backward	5°	
Maximum shoulder reach outside of tires		
– right	1905 mm	75 in
– left	1742 mm	68.6 in
Maximum lift above ground	427 mm	16.8 in
Maximum depth of cut	720 mm	28.3 in

### Scarifier

Mid, V-Type		
Working width	1184 mm	46.6 in
Scarifying depth, maximum	292 mm	11.5 in
Scarifier shank holders	11	
Scarifier shank holder spacing	116 mm	4.6 in

### Weights

Gross Vehicle Weight – no armor		
– total	17,726 kg	39,080 lb
– front axle	5,366 kg	11,830 lb
– rear axle	12,360 kg	27,250 lb
Gross Vehicle Weight – with armor		
– total	20,452 kg	45,090 lb
– front axle	6,205 kg	13,680 lb
– rear axle	14,247 kg	31,410 lb

- Base operating weight calculated on standard machine configuration with 14.00 R24 tires, full fuel tank, coolant, lubricants and operator.

### Standards

ROPS/FOPS	ISO 3471:1992/ISO 3449:1992
Steering	ISO 5010:1992
Brakes	ISO 3450:1996
Sound	ISO 6394:1998/ISO 6395:1988

- The static sound operator pressure level measured according to ISO 6394:1988 for a cab offered by Caterpillar, when properly installed, maintained and tested with doors and windows closed and hydraulic fan at maximum speed is 70 dB(A).
- The dynamic spectator sound power level for the standard machine when equipped with sound suppression package and hydraulic fan running at 70% of maximum speed, machine sound measured is less than 105 dB(A), complying with EU 2000/14/EC requirement.

Transmission (USN, USMC)	133 kg	293 lb
Air conditioner with heater	49 kg	107 lb
Mirrors, outside: mounted	10 kg	22 lb
All Wheel Drive	590 kg	1,300 lb
Precleaner, Sy-Klone (USMC)	9 kg	20 lb
Accumulators, blade lift (USN, USMC)	77 kg	170 lb
Camera, rearview (USMC)	7 kg	15 lb
Compressor/tank, Air (USN, USMC)	23 kg	50 lb
Starting aid, Ether	0.5 kg	1 lb
Mid Mount Scarifier	959 kg	2,114 lb
Fan, defroster, rear window	2 kg	4 lb

## DIMENSIONS

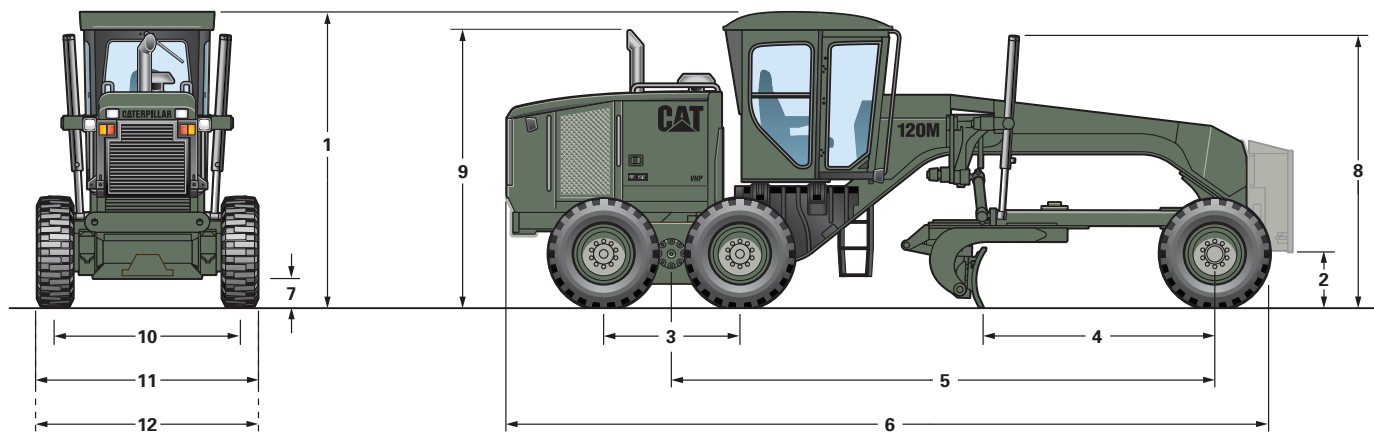

1	Height – top of cab	3278 mm	131 in
2	Height – front axle center	610 mm	24 in
3	Length – between tandem axles	1511 mm	59.5 in
4	Length – front axle to moldboard	2511 mm	98.9 in
5	Length – front axle to mid tandem	5915 mm	232.8 in
6	Length – front tire to rear of machine	8488 mm	334.1 in

7	Ground clearance at rear axle	363 mm	14.3 in
8	Height to top of cylinders	2934 mm	115.5 in
9	Height to exhaust stack	2883 mm	113.5 in
10	Width – tire center lines	2096 mm	82.5 in
11	Width – outside rear tires	2565 mm	101 in
12	Width – outside front tires	2540 mm	100 in

## STANDARD EQUIPMENT

*Standard equipment may vary. Consult Caterpillar Defense & Federal Products for details.*

### Operator Environment

- Arm/wrist rest, adjustable
- Articulation, automatic Return-to-Center
- Ashtray and lighter
- Cat Messenger, operator information system
- Centershift pin indicator
- Coat hook
- Cup holder
- Display, digital speed and gear
- Door, driver access (left side) with wiper
- Gauge cluster – articulation, engine coolant temp, engine RPM, fuel, system voltage
- Gauge, machine level
- Heater, cab
- Hour meter, digital
- Joystick hydraulic controls
  - implements, steering, transmission
- Messenger Operator Info System
- Mirror, inside rearview, wide angle outside mirrors
- Power port, 12V
- ROPS cab, sound suppressed
- Seat belt, retractable 76 mm (3 in)
- Seat, cloth-covered, comfort suspension
- Storage area for cooler/lunchbox
- Throttle control, electronic
- Windows, laminated glass:
  - door, left with dual wipers
  - fixed, window right with dual wipers
  - fixed front with intermittent wiper
- Windows, tempered glass
  - side and rear (3)
- Wrist rests, adjustable

### Power Train

- Air cleaner, dual stage, dry type, automatic dust ejector, service indicator through Cat Messenger
- Air-to-air after cooler (ATAAC)
- Belt, serpentine, automatic tensioner
- Brakes, four-wheel hydraulic
- Differential, lock/unlock
- Drain, engine oil
- Electronic over speed protection
- Engine, Cat® C6.6 with ACERT™ Technology
- Fuel-water separator
- Hydraulic demand fan
- Muffler, under hood
- Parking brake – multi-disc, sealed, oil-cooled
- Priming pump, fuel
- Rear axle, modular
- Sediment drain, fuel tank
- Transmission, 8F/6R, power shift, direct drive
- VHP (Variable Horsepower)

### Electrical

- Alarm, back up
- Alternator, 150 ampere, sealed
- Batteries, maintenance free, 1400 CCA (x2)
- Breaker panel, ground accessible
- Electrical system, 24V
- Grade Control Ready – Cab harness, software, electrical hydraulic valves, bosses and brackets
- Lights, reversing
- Lights, stop and tail, LED

### Other Standard Equipment

- Brake accumulators, dual certified
- Bumper, rear, integrated with hitch
- Clutch, circle drive slip
- Cutting edges
  - curved DH-2 steel
  - 203 mm 16 mm (8 in 5/8 in)
  - 19 mm (3/4 in) mounting bolts
- Doors (3), engine compartment, locking
- Drawbar – 4 shoes with replaceable wear strips
- Endbits
  - 16 mm (5/8 in) DH-2 steel
  - 19 mm (3/4 in) mounting bolts
- Extended Life Coolant to –35° C (–30° F)
- Fluid check, ground level
- Frame, articulated, with safety lock
- Fuel tank, ground level access
- Ground level engine shutdown
- Hammer (emergency exit)
- Horn, electric
- Hydraulics, base 8 implement controls
- Hydraulics, load-sensing
- Lockout, hydraulic implement for roading
- Moldboard
  - 3658 mm 610 mm 22 mm (12 ft 24 in 7/8 in)
  - hydraulic sideshift and tip
- Anti-glare paint – top of front frame and rear enclosure
- Radiator cleanout access
- Secondary steering
- Serviceability, LH side
- S•O•S<sup>SM</sup> ports: engine, hydraulic, transmission, coolant, fuel
- Tandem walkway/guards
- Tool box
- Tow hitch

### Tires, Rims, & Wheels

- 14R24 tires on multi-piece rims



## MILITARY MODIFICATIONS

- Armored Cab (Optional)
- Split Cab
- NATO Start Receptacle
- Blackout Lighting System
- Keyless Engine Start Switch
- Rifle Bracket
- Military Data Plates
- Shipping Data Plates
- Cold Start Aid for -25° F (Ether)
- Arctic Kit for Cold Start (-40° F) (Optional)
- Military Towing Lugs
- Decontamination Bracket
- Vandalism Protection
- Removable Glass
- Fresh Water Fordable to 30" Depth
- Reduced Lift Cylinder Mounting Arrangement for Transport
- Hinged Battery Access Door
- Scarifier Tooth Storage Rack
- MIL-STD-209 Lift and Tiedown Provisions
- Tool Box
- Fire Extinguisher
- External Mirrors
- CARC or Special Paint

For more information visit: [www.catdfp.com](http://www.catdfp.com)

*All dimensions are approximate. Dimensions may vary with configuration. Specific military service configurations are available upon request.*

© 2009 Caterpillar | All Rights Reserved | Printed in the USA

Materials and specifications are subject to change without notice. Featured machines may include additional equipment. See your account manager for available options.

CAT, CATERPILLAR, their respective logos, "Caterpillar Yellow" and the POWER EDGE trade dress, as well as corporate and product identity used herein, are trademarks of Caterpillar and may not be used without permission.

