

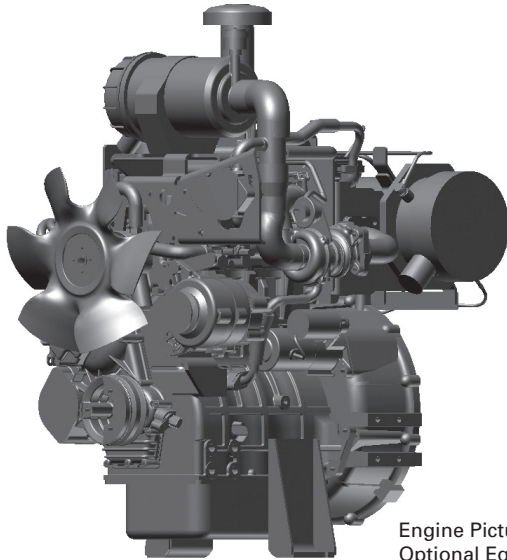

C1.5 Industrial Engine

Tier 4 Final

25.2-27.6 kW/33.8-37 bhp @ 2400-3000 rpm



Engine Pictured with
Optional Equipment

CAT® ENGINE SPECIFICATIONS

I-3, 4-Stroke-Cycle Diesel

Bore	84 mm (3.31 in)
Stroke	90 mm (3.54 in)
Displacement	1.496 L (91.0 in ³)
Aspiration	Turbocharged
Compression Ratio	22.5:1
Combustion System	Indirect Injection
Rotation (from flywheel end)	Counterclockwise
Capacity for Liquids	
Cooling System (engine only)	2.6 L (2.8 U.S. qts)
Lube Oil System (refill)	6 L (6.3 U.S. qts)
Engine Weight, Net Dry (approx)	
with standard equipment	175 kg (385.8 lb)

FEATURES

Emissions

Meets 2013 U.S. EPA Tier 4 Final emission standards.

Reliable, Quiet and Durable Power

World-class manufacturing capability and processes coupled with proven core engine designs assure reliability, quiet operation, and many hours of productive life.

High Performance

Substantial torque rise delivers impressive performance through a wide speed range while maintaining low operating costs

Fuel Efficiency

Fuel consumption optimized to match operating cycles of a wide range of equipment and applications.

Broad Application Range

Industry-leading range of factory configurable ratings and options for agricultural, materials-handling, construction, mining, aircraft ground support, and other industrial applications.

Package Size

Ultra-compact package size ensures ease of installation as well as exceptional power density.

Low-Cost Maintenance

Single-side servicing improves ease of maintenance and simplifies the servicing routine. Service intervals at 500 hours are standard.

Testing

Every Cat® engine is quality tested to ensure proper engine performance.

World-class Product Support Offered Through Global Cat Dealer Network

- Scheduled maintenance
- Customer Support Agreements (CSA)
- Caterpillar Extended Service Coverage (ESC)
- Superior dealer service network
- Extended dealer service network through the Cat Industrial Service Distributor (ISD) program

Web Site: For additional information on all your power requirements, visit www.cat-industrial.com.



C1.5 Industrial Engine

Tier 4 Final

25.2-27.6 kW/33.8-37 bhp @ 2400-3000 rpm

STANDARD EQUIPMENT

Air Inlet

Inlet manifold with choice of inlets

Control System

Alternator 12V 85A, starter motor 12V, glow plug starting aid

Cooling System

Belt-driven coolant pump, coolant temperature switch, choice of cooling fans

Flywheel & Flywheel Housing

SAE No. 7-1/2 flywheel, choice of SAE No. 4 or SAE No. 5 or standard backplate flywheel housing

Fuel System

Simple, robust indirect injection fuel pump, spin-on fuel filter

Lube System

Alternative oil fillers, spin-on lube oil filter, lube oil pressure switch, lube oil sump

Power Take-Off

SAE A PTO drive

General

Cast iron engine block, cast iron exhaust manifold – side outlet, cold start capability to -20°C (-4°F), gradeability 35° continuous

DIMENSIONS

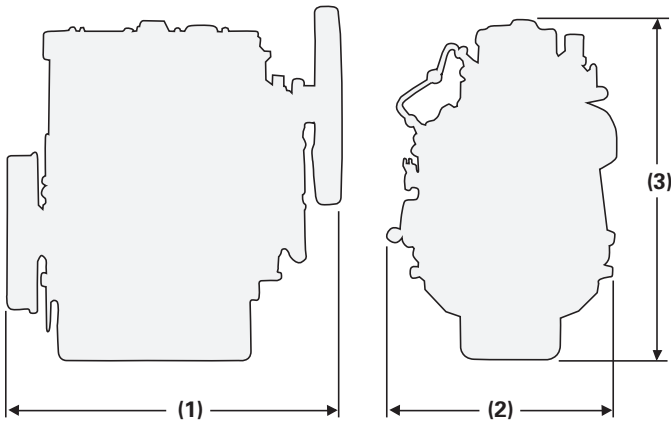

(1) Length	577.3 mm (22.7 in)
(2) Width	624 mm (24.6 in)
(3) Height	712 mm (28 in)



C1.5 Industrial Engine

Tier 4 Final

25.2-27.6 bkW/33.8-37 bhp @ 2400-3000 rpm

PERFORMANCE DATA — PRELIMINARY

Turbocharged — 2400-3000 rpm

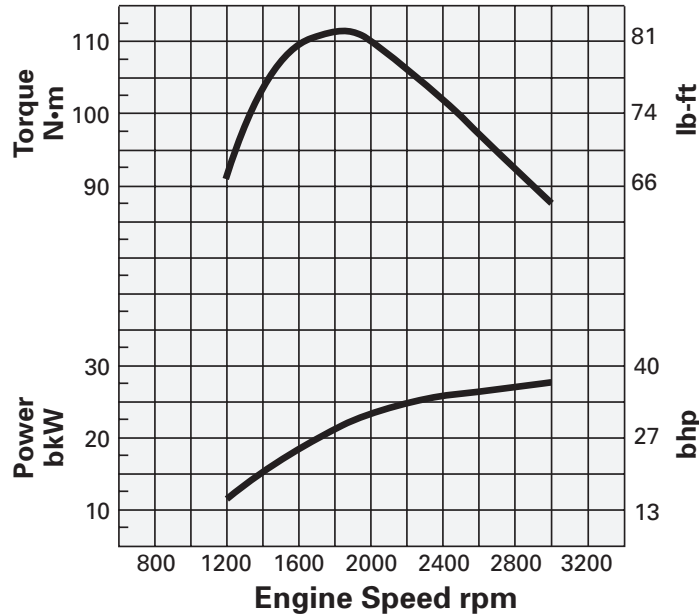

Rating	Speed rpm	Peak Power bkW	Peak Power bhp	Speed rpm	Peak Torque N·m	Peak Torque lb-ft
C	3000	27.6	37.0	1800	112.0	82.6

RATING DEFINITIONS AND CONDITIONS

IND-C (Intermittent) is the horsepower and speed capability of the engine where maximum power and/or speed are cyclic (time at full load not to exceed 50%).

Additional ratings are available for specific customer requirements. Consult your Cat dealer.

Rating Conditions for Diesel Engines — up to 7.1 liter are based on ISO/TR14396, inlet air standard conditions with a total barometric pressure of 100 kPa (29.5 in. Hg), with a vapor pressure of 1 kPa (.295 in. Hg), and 25°C (77°F). Performance is measured using fuel to specification U.S. EPA 2D 89.330-96 with a density of 0.845-0.850 kg/L @ 15°C (59°F) and fuel inlet temperature 40°C (104°F).



C1.5 Industrial Engine

Tier 4 Final

25.2-27.6 kW/33.8-37 bhp @ 2400-3000 rpm

AFTERTREATMENT CONFIGURATION

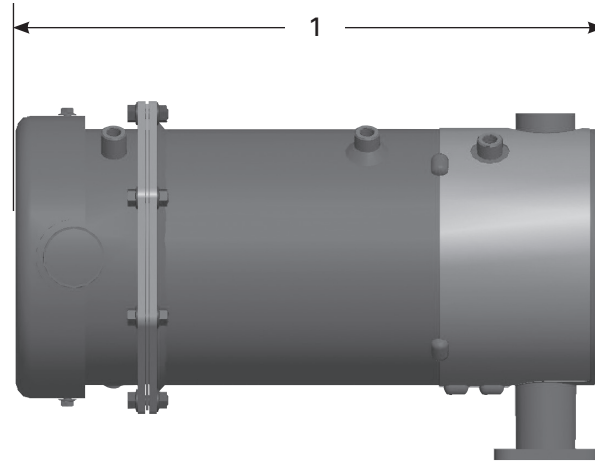

Images shown may not reflect actual aftertreatment.

170 mm (6.7 in) Diameter Base Configuration

Approximate Size and Weight

(1) Length — 449 mm (17.6 in)

Weight — 13 kg (28.7 lbs)

Note: Final weight and dimensions will depend on completed specification.

AFTERTREATMENT FEATURES

Regeneration:

Highly effective passive regeneration under most operating environments and cycles. Automatic, transparent active regeneration backup system during light load or adverse operating cycles. Wall flow DPF and through-flow DOC to effectively remove and manage emissions.

Mounting: Multiple off- and on-engine installation options provide customers with simple and flexible solutions for many applications.

Service: Minimum 3,000 hour DPF ash service intervals.

STANDARD EMISSIONS CONTROL EQUIPMENT

DPF: Diesel Particulate Filter with range of outlet options

DOC: Diesel Oxidation Catalyst

Materials and specifications are subject to change without notice. The International System of Units (SI) is used in this publication. CAT, CATERPILLAR, their respective logos, S•O•S, "Caterpillar Yellow" and the "Power Edge" trade dress, as well as corporate and product identity used herein, are trademarks of Caterpillar and may not be used without permission.