



Cat[®] TH407C

TELEHANDLER

Specifications

Engine

Model	Cat [®] C4.4 ACERT™*
Gross Power	
Standard	74.5 kW/101 hp
Optional	93.1 kW/126 hp
Maximum Torque	
Standard	410 N·m/1,400 rpm
Optional	496 N·m/1,400 rpm
Bore	105 mm
Stroke	127 mm
Displacement	4.4 L

- All engine horsepower (hp) are metric.

*Meets EU Stage IIIA and U.S. EPA Tier 3 equivalent emission standards.

Weights

Operating Weight with Carriage & Forks	8730 kg
--	---------

Operating Specifications

Rated Load Capacity	3700 kg
Maximum Lift Height	7300 mm
Maximum Forward Reach	3763 mm
Top Travel Speed	40 km/h
Load at Maximum Height	2000 kg
Load at Maximum Reach	1500 kg
Outside Turning Radius Over Tires	3750 mm
Outside Turning Radius Over Forks	4740 mm

Hydraulic System

Maximum System Pressure	250 bar
Maximum Pump Flow	150 L/min
Pump Type	Variable Displacement Load Sensing Axial Piston Pump
Auxiliary Hydraulic Supply	
Intermittent	80 L/min
Continuous	60 L/min

Service Refill Capacities

Fuel Tank	150 L
Hydraulic Tank	90 L

Tires

Standard	15.5/80-24 16PR
----------	-----------------

Brakes

Service Brakes	Servo Assisted on Front Axle
Parking Brakes	Mechanical on Front Axle

Transmission Speeds

	C4.4 ACERT Engine Only	C4.4 ACERT Engine Only
Forward		
1	6.8 km/h	6.6 km/h
2	13.3 km/h	10 km/h
3	19.8 km/h	13 km/h
4	30.5 km/h	19.3 km/h
5	—	29.6 km/h
6	—	40 km/h
Reverse		
1	6.8 km/h	6.6 km/h
2	13.3 km/h	13 km/h
3	30.5 km/h	29.6 km/h

Boom Performance

Boom Up	7.6 Seconds
Boom Down	5.9 Seconds
Tele In	5.3 Seconds
Tele Out	6.4 Seconds
Crowd Forward (dump)	2.4 Seconds
Crowd Backward	2.8 Seconds
Combined	
Up and Out	11.5 Seconds
Down and In	6.6 Seconds
Drawbar Pull	
Standard	78 kN
Option 1	85 kN
Bucket Breakout Force to ISO 8313	65 kN
Boom Breakout Force	42 kN

Sound

Operator Sound	78 dB(A)
Exterior Sound	74.5 kW – 106 dB(A) 93.1 kW – 107 dB(A)



TH407C Telehandler

Dimensions

All dimensions are approximate.

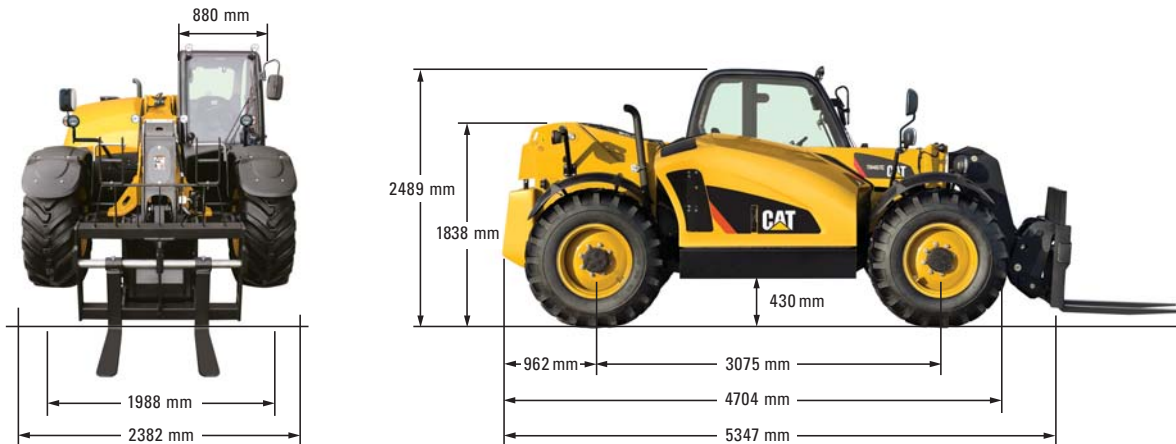

Load Chart and Dimensions

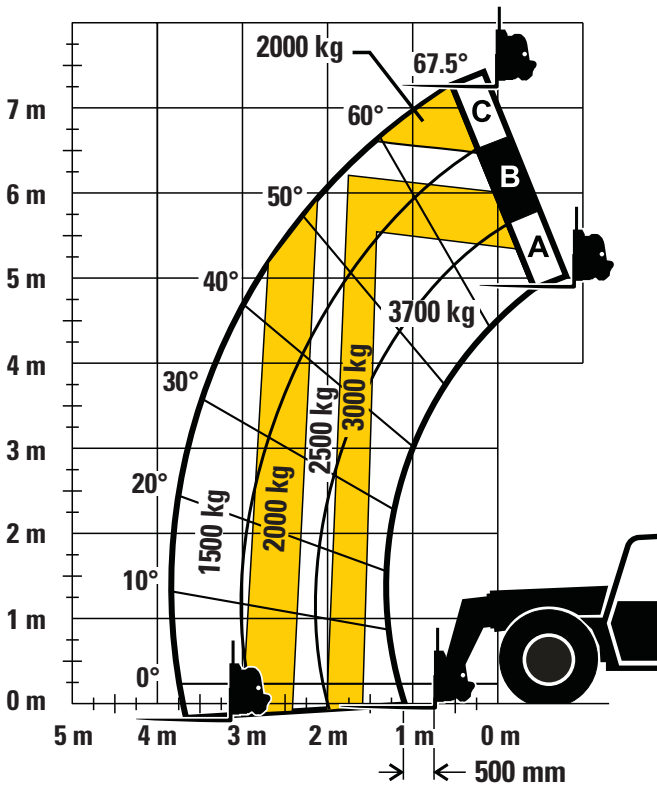

IMPORTANT

Rated lift capacities shown are with machine equipped with carriage and pallet forks. The machine must be level on a firm surface with undamaged, properly inflated tires. Machine specifications and stability are based on rated lift capacities at specific boom angles and boom lengths. (If specifications are critical, the proposed application should be discussed with your dealer.)

DO NOT exceed rated lift capacity loads, as unstable and dangerous machine conditions will result.

DO NOT tip the machine forward to determine the allowable load.

Due to continuous product improvements, machine specifications and/or equipment changes may be made without prior notification.

For more complete information on Cat products, dealer services, and industry solutions, visit us on the web at www.cat.com

© 2016 Caterpillar
All rights reserved

Materials and specifications are subject to change without notice. Featured machines in photos may include additional equipment. See your Cat dealer for available options.

CAT, CATERPILLAR, SAFETY.CAT.COM, their respective logos, "Caterpillar Yellow" and the "Power Edge" trade dress, as well as corporate and product identity used herein, are trademarks of Caterpillar and may not be used without permission.

AEHQ7022-01 (03-2016)
Replaces AEHQ7022

