



Cat[®] 299D

COMPACT TRACK LOADER

FEATURES:

The Cat[®] 299D Compact Track Loader, with its vertical lift design, delivers extended reach and lift height for quick and easy truck loading. Its standard, suspended undercarriage system provides superior traction, flotation, stability and speed to work in a wide range of applications and underfoot conditions. The 299D features the following:

- **Industry leading sealed and pressurized cab option** provides a cleaner and quieter operating environment with excellent Work Tool visibility.
- **Available high-back, heated, air ride seat with seat mounted adjustable joystick controls** makes the D Series the industry leader in operator comfort.
- **High performance power train** provides maximum performance and production capability through the Electronic Torque Management system, standard two speed travel and an industry exclusive electronic hand/foot throttle with decel pedal capability.
- **High Flow XPS hydraulic system** is available for applications that demand maximum hydraulic work tool performance.
- **Electronically controlled Cat C3.8 engine** provides high horsepower and torque while meeting U.S. EPA Tier 4 Interim (EU Stage IIIB) emission standards.
- **Cat "Intelligent Leveling" system (ILEV)** provides industry leading technology, integration and optional features such as dual direction self level, work tool return to dig and work tool positioner.
- **Standard fully independent torsion axle suspension** combined with the optional Speed Sensitive Ride Control system improves operation on rough terrain, enabling better load retention, increased productivity and greater operator comfort.
- **Maximize machine capability and control** with optional Advanced Display providing on-screen adjustments for implement response, hystat response, and creep control, multi-language functionality with customizable layouts, security system, and rearview camera.
- **Ground level access** to all daily service and routine maintenance points helps reduce machine downtime for greater productivity.
- **Broad range of performance matched Cat Work Tools** make the Cat Compact Track Loader the most versatile machine on the job site.

Specifications

Engine

Engine Model	Cat C3.8 DIT (turbo)	
Gross Power SAE J1995	73 kW	98 hp
Net Power SAE 1349	71 kW	95 hp
Net Power ISO 9249	71 kW	95 hp
Peak Torque at 1,500 rpm SAE J1995	334 N-m	246 lbf-ft
Displacement	3.8 L	232 in ³
Stroke	120 mm	4.7 in
Bore	100 mm	3.9 in

Weights*

Operating Weight	4862 kg	10,718 lb
------------------	---------	-----------

Power Train

Travel Speed (Forward or Reverse):		
One Speed	8.4 km/h	5.2 mph
Two Speed	13.5 km/h	8.4 mph

*Operating Weight, Operating Specifications and Dimensions all based on 75 kg (165 lb) operator, all fluids, two speed, OROPS, 1981 mm (78 in) dirt bucket, 400 mm (15.7 in) tracks, dual flange front idler/single flange rear idler, standard flow hydraulics, mechanical suspension seat, no optional counterweights and manual quick coupler (unless otherwise noted).

Hydraulic System

Hydraulic Flow – Standard:			
Loader Hydraulic Pressure	23 000 kPa	3,335 psi	
Loader Hydraulic Flow	86 L/min	23 gal/min	
Hydraulic Power (calculated)	33 kW	44 hp	
Hydraulic Flow – High Flow XPS:			
Maximum Loader Hydraulic Pressure	28 000 kPa	4,061 psi	
Maximum Loader Hydraulic Flow	121 L/min	32 gal/min	
Hydraulic Power (calculated)	57 kW	76 hp	

Operating Specifications*

Rated Operating Capacity:			
35% Tipping Load	1350 kg	2,975 lb	
50% Tipping Load	1928 kg	4,250 lb	
Rated Operating Capacity with Optional Counterweight			
Tipping Load	2041 kg	4,500 lb	
Breakout Force, Tilt Cylinder	3855 kg	8,500 lb	
Breakout Force, Lift Cylinder	3426 kg	7,552 lb	
Breakout Force, Lift Cylinder	2777 kg	6,122 lb	
Ground Contact Area (400 mm/15.7 in track)	1.41 m ²	2,184 in ²	
Ground Contact Area (450 mm/17.7 in track)	1.59 m ²	2,463 in ²	
Ground Pressure (400 mm/15.7 in track)	33.8 kPa	4.9 psi	
Ground Pressure (450 mm/17.7 in track)	30.1 kPa	4.4 psi	



299D Compact Track Loader

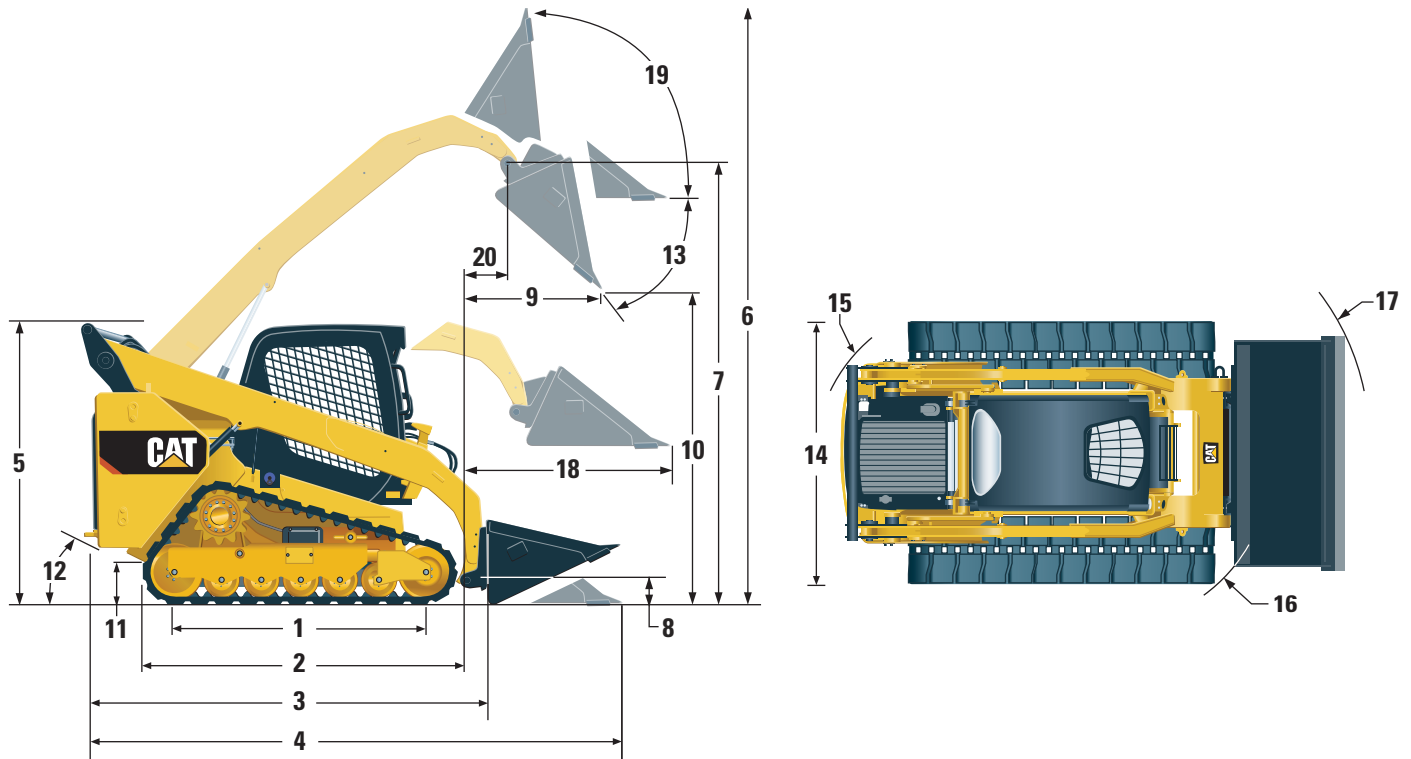

Dimensions*

1	Length of Track on Ground	1767 mm	69.6 in
2	Overall Length of Track	2270 mm	89.4 in
3	Length without Bucket	3136 mm	123.5 in
4	Length with Bucket on Ground	3855 mm	151.8 in
5	Height to Top of Cab	2127 mm	83.7 in
6	Maximum Overall Height	4024 mm	158.4 in
7	Bucket Pin Height at Maximum Lift	3191 mm	125.6 in
8	Bucket Pin Height at Carry Position	200 mm	7.9 in
9	Reach at Maximum Lift and Dump	778 mm	30.6 in
10	Clearance at Maximum Lift and Dump	2395 mm	94.3 in
11	Ground Clearance	222 mm	8.7 in
12	Departure Angle		30°
13	Maximum Dump Angle		52°
14	Vehicle Width (400 mm/15.7 in tracks)	1931 mm	76.0 in
	Vehicle Width (450 mm/17.7 in tracks)	1981 mm	78.0 in
15	Turning Radius from Center – Machine Rear	1863 mm	73.4 in
16	Turning Radius from Center – Coupler	1474 mm	58.0 in
17	Turning Radius from Center – Bucket	2317 mm	91.2 in
18	Maximum Reach with Arms Parallel to Ground	1276 mm	50.2 in
19	Rack Back Angle at Maximum Height		83°
20	Bucket Pin Reach at Maximum Lift	396 mm	15.6 in

Cab

ROPS	ISO 3471:2008
FOPS	ISO 3449:2005 Level I
FOPS Level II	ISO 3449:2005 Level II

Service Refill Capacities

Cooling System	16 L	4.1 gal
Engine Crankcase	13 L	3.5 gal
Fuel Tank	122 L	32.2 gal
Hydraulic System	55 L	14.5 gal
Hydraulic Tank	39 L	10.3 gal

MANDATORY EQUIPMENT

- Hydraulics, Standard or High Flow XPS
- Quick Coupler, Mechanical or Electric
- Seat Belt, 50 mm (2 in) or 75 mm (3 in)
- Steel Imbed Rubber Track – 400 mm (15.7 in) or 450 mm (17.7 in)
- Dual Flange Front Idler/Single Flange Rear Idler or Triple Flange Front/Rear Idlers

PERFORMANCE PACKAGE *(must select one of the following)*

- Performance Package H1: *Standard Flow (No Self Level)*
- Performance Package H2: *Standard Flow, Dual Direction Electronic Self Level (Raise and Lower, Electronic Snubbing (Raise and Lower)*
- Performance Package H3: *High Flow XPS, Dual Direction Electronic Self Level (Raise and Lower), Electronic Snubbing (Raise and Lower)*

STANDARD EQUIPMENT

ELECTRICAL

- 12 volt Electrical System
- 100 ampere Alternator
- Ignition Key Start/Stop Switch
- Lights: *Gauge Backlighting, Two Rear Tail Lights, Two Rear Halogen Working Lights, Two Adjustable Front Halogen Lights, Dome Light*
- Backup Alarm
- Heavy Duty Battery, 880 CCA

OPERATOR ENVIRONMENT

- Gauges: *Fuel Level, Hour Meter*
- Operator Warning System Indicators: *Air Filter Restriction, Alternator Output, Armrest Raised/Operator Out of Seat, Engine Coolant Temperature, Engine Oil Pressure, Air Inlet Heater Activation, Hydraulic Filter Restriction, Hydraulic Oil Temperature, Park Brake Engaged, Engine Emission System*
- Adjustable Vinyl Seat
- Fold In Ergonomic Contoured Armrest
- Control Interlock System, when operator leaves seat or armrest raised: *Hydraulic System Disables, Hydrostatic Transmission Disables, Parking Brake Engages*
- ROPS Cab, Open, Tilt Up
- FOPS, Level I
- Top and Rear Windows
- Floor Mat
- Interior Rearview Mirror
- 12 volt Electric Socket
- Horn
- Hand (Dial) Throttle, Electronic
- Adjustable Joystick Controls
- Anti-theft Security System with 6-button Keypad
- Storage Compartment with Netting

OPTIONAL ATTACHMENTS

- External Counterweights
- Beacon, Rotating
- Engine Block Heater – 120V
- Oil, Hydraulic, Cold Operation
- Paint, Custom
- Heavy Duty Battery, 1,000 CCA
- Product Link™, Cellular

COMFORT PACKAGE *(must select one of the following)*

- Open ROPS (C0): *Static Seat (No Foot Throttle, Headliner, Heater or Door)*
- Open ROPS (C1): *Foot Throttle, Headliner, Cup Holder, and choice of Seat (Mechanical Suspension or High Back, Heated, Air Ride Seat) (No Heater or Door)*
- Enclosed ROPS with Heater (C2): *Foot Throttle, Headliner, Heater and Defroster, Side Windows, Cup Holder, Radio Ready, choice of Seat (Mechanical Suspension or High Back, Heated, Air Ride Seat) and Door (Glass or Polycarbonate)*
- Enclosed ROPS with A/C (C3): *C2 + Air Conditioner*

POWER TRAIN

- Cat C3.8, Turbo Diesel Engine, Meeting U.S. EPA Tier 4 Interim (EU Stage IIIB) Emission Standards
- Air Cleaner, Dual Element, Radial Seal
- S-O-SSM Sampling Valve, Hydraulic Oil
- Filters, Cartridge-type, Hydraulic
- Filters, Cartridge-type, Fuel and Water Separator
- Radiator/Hydraulic Oil Cooler (side-by-side)
- Spring Applied, Hydraulically Released, Wet Multi Disc Parking Brakes
- Hydrostatic Transmission, Two Speed Travel
- Suspension – Independent Torsion Axles (4)

OTHER

- Engine Enclosure, Lockable
- Extended Life Antifreeze, –37° C (–34° F)
- Machine Tie Down Points (6)
- Support, Lift Arm
- Hydraulic Oil Level Sight Gauge
- Radiator Coolant Level Sight Gauge
- Radiator, Expansion Bottle
- Cat ToughGuard™ Hose
- Auxiliary, Hydraulics, Continuous Flow
- Heavy Duty, Flat Faced Quick Disconnects with Integrated Pressure Release
- Split D-Ring to Route Work Tool Hoses Along Side of Left Lift Arm
- Electrical Outlet, Beacon
- Belly Pan Cleanout
- Variable Speed Demand Fan

- Ride Control
- Advanced Display: Full Color, 5 in LCD screen, Advanced Multi-operator Security System, On-screen Adjustments for Implement Response, Hystat Response, and Creep Control; Rearview Camera Ready
- Advanced Display: Rearview Camera Included
- Work Tool Return to Dig and Work Tool Positioner
- Bluetooth Radio with Microphone (AM/FM/Weather Band Receiver with USB and Auxiliary Input Jack)

299D Compact Track Loader

For more complete information on Cat products, dealer services, and industry solutions, visit us on the web at www.cat.com

© 2013 Caterpillar Inc.
All Rights Reserved
Printed in U.S.A.

Materials and specifications are subject to change without notice. Featured machines in photos may include additional equipment. See your Cat dealer for available options.

CAT, CATERPILLAR, SAFETY.CAT.COM, their respective logos, "Caterpillar Yellow" and the "Power Edge" trade dress, as well as corporate and product identity used herein, are trademarks of Caterpillar and may not be used without permission.

AEHQ7013 (07-13)
(NACD, EU, AUZ)

