

966G Series II Wheel Loader

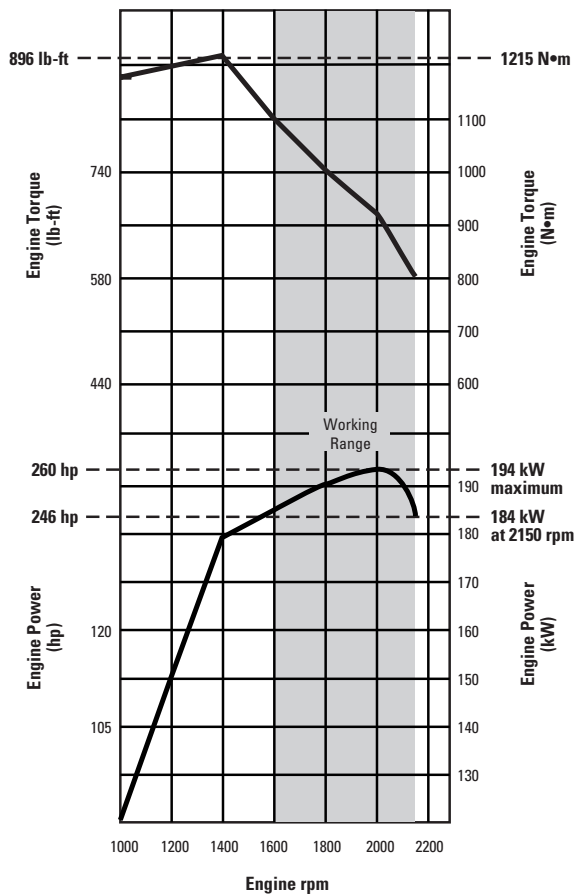

966G Series II Wheel Loader

Operation Specifications

		General Purpose Buckets								
		Bolt-on edges			Teeth and segments			Teeth		
		Bolt-on edges	Teeth and segments	Teeth	Bolt-on edges	Teeth and segments	Teeth	Bolt-on edges	Teeth and segments	Teeth
Rated capacity	m ³	4.25	4.25	4.0	4.0	4.0	3.8	3.8	3.8	3.65
	yd ³	5.5	5.5	5.25	5.25	5.25	5.0	5.0	5.0	4.75
Struck capacity	m ³	3.62	3.62	3.43	3.43	3.43	3.28	3.27	3.27	3.12
	yd ³	4.7	4.7	4.46	4.46	4.46	4.27	4.25	4.25	4.06
Width	mm	3220	3311	3311	3059	3150	3150	3059	3150	3150
	ft/in	10'6"	10'10"	10'10"	10'0"	10'4"	10'4"	10'0"	10'4"	10'4"
Dump clearance at full lift and 45° discharge	mm	3066	2929	2929	3066	2929	2929	3100	2963	2963
	ft/in	10'0"	9'7"	9'7"	10'0"	9'7"	9'7"	10'2"	9'8"	9'8"
Reach at full lift and 45° discharge	mm	1328	1449	1449	1328	1449	1449	1304	1426	1426
	ft/in	4'4"	4'9"	4'9"	4'4"	4'9"	4'9"	4'3"	4'8"	4'8"
Reach with lift arms horizontal and bucket level	mm	2736	2917	2917	2736	2917	2917	2694	2875	2875
	ft/in	8'11"	9'6"	9'6"	8'11"	9'6"	9'6"	8'10"	9'5"	9'5"
Digging depth	mm	129	129	99	129	129	99	129	129	99
	in	5.0"	5.0"	3.8"	5.0"	5.0"	3.8"	5.0"	5.0"	3.8"
Overall length	mm	8870	9073	9073	8870	9073	9073	8828	9031	9031
	ft/in	29'1"	29'9"	29'9"	29'1"	29'9"	29'9"	28'11"	29'7"	29'7"
Overall height with bucket at full raise	mm	5832	5832	5832	5832	5832	5832	5794	5794	5794
	ft/in	19'1"	19'1"	19'1"	19'1"	19'1"	19'1"	19'0"	19'0"	19'0"
Loader clearance circle with bucket in carry position	mm	14 726	14 923	14 923	14 578	14 776	14 776	14 557	14 754	14 754
	ft/in	48'3"	48'11"	48'11"	47'9"	48'5"	48'5"	47'9"	48'4"	48'4"
Static tipping load, straight**	kg	16 280	16 110	16 270	16 350	16 180	16 470	16 310	16 140	16 440
	lb	35,881	35,506	35,859	36,035	35,661	36,300	35,947	35,573	36,234
Static tipping load, articulated at full 37° turn	kg	14 470	14 310	14 460	14 540	14 380	14 650	14 500	14 330	14 610
	lb	31,892	31,539	31,870	32,046	31,694	32,289	31,958	31,583	32,200
Breakout force***	kN	189.1	187.9	201.1	189.4	188.3	201.5	196.7	195.6	209.6
	lb	42,477	42,221	45,184	42,562	42,306	45,260	44,189	43,940	47,092
Operating weight**	kg	22 868	23 041	22 875	22 794	22 967	22 813	22 748	22 921	22 767
	lb	50,401	50,782	50,417	50,238	50,619	50,280	50,137	50,518	50,178

Standard Lift Bucket Selection Guide/Material Density

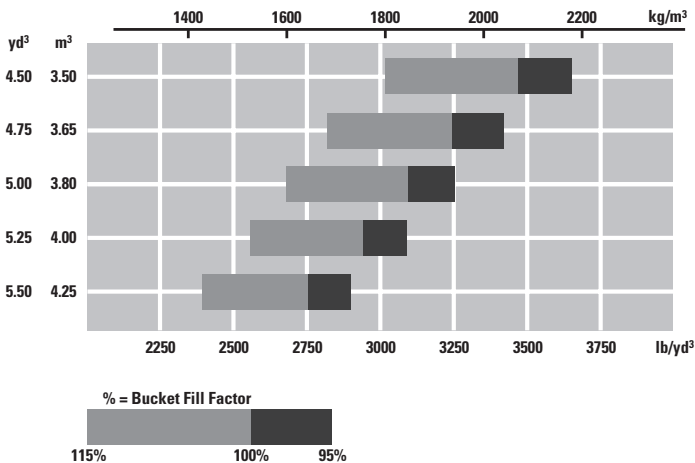

966G Series II Wheel Loader

			Material Handling Buckets						Rock Buckets		Heavy-Duty Rock Buckets	
Bolt-on edges	Teeth and segments	Teeth	Bolt-on edges	Teeth and segments	Teeth	Bolt-on edges	Teeth and segments	Teeth	Bolt-on edges	Teeth and segments	Bolt-on edges	Teeth and segments
3.65 4.75	3.65 4.75	3.5 4.5	4.0 5.25	4.0 5.25	3.8 5.0	3.8 5.0	3.8 5.0	3.65 4.75	3.5 4.5	3.5 4.5	3.5 4.5	3.5 4.5
3.1 4.04	3.1 4.04	2.96 3.85	3.46 4.49	3.46 4.49	3.31 4.3	3.22 4.18	3.22 4.18	3.08 4.0	3.0 3.9	3.0 3.9	3.0 3.9	3.0 3.9
3059 10'0"	3150 10'4"	3150 10'4"	3220 10'6"	3311 10'10"	3311 10'10"	3220 10'6"	3311 10'10"	3311 10'10"	3306 10'10"	3252 10'8"	3306 10'10"	3252 10'8"
3135 10'3"	2999 9'10"	2999 9'10"	3021 9'10"	2874 9'5"	2874 9'5"	3063 10'0"	2916 9'6"	2916 9'6"	2952 9'8"	2756 9'0"	2952 9'8"	2756 9'0"
1281 4'2"	1404 4'7"	1404 4'7"	1204 3'11"	1313 4'3"	1313 4'3"	1162 3'9"	1270 4'2"	1270 4'2"	1273 4'2"	1381 4'6"	1273 4'2"	1381 4'6"
2651 8'8"	2832 9'3"	2832 9'3"	2701 8'10"	2882 9'5"	2882 9'5"	2641 8'7"	2822 9'3"	2822 9'3"	2799 9'2"	3013 9'10"	2799 9'2"	3013 9'10"
129 5.0"	129 5.0"	99 3.8"	129 5.0"	129 5.0"	99 3.8"	129 5.0"	129 5.0"	99 3.8"	129 5.0"	129 5.0"	129 5.0"	129 5.0"
8785 28'9"	8988 29'5"	8988 29'5"	8835 28'11"	9038 29'7"	9038 29'7"	8775 28'9"	8978 29'5"	8978 29'5"	8933 29'3"	9196 30'2"	8933 29'3"	9196 30'2"
5754 18'10"	5754 18'10"	5754 18'10"	5783 18'11"	5783 18'11"	5783 18'11"	5727 18'9"	5727 18'9"	5727 18'9"	5716 18'9"	5716 18'9"	6042 19'9"	6042 19'9"
14 535 47'8"	14 732 48'3"	14 732 48'3"	14 709 48'3"	14 905 48'10"	14 905 48'10"	14 679 48'1"	14 874 48'9"	14 874 48'9"	14 837 48'8"	14 945 49'0"	14 837 48'8"	14 945 49'0"
16 440 36,234	16 270 35,859	16 570 36,520	16 080 35,440	15 910 35,066	16 210 35,727	16 180 35,661	16 020 35,308	16 320 35,969	16 350 36,035	16 260 35,837	16 190 35,678	16 100 35,484
14 620 32,222	14 450 31,848	14 730 32,465	14 290 31,495	14 120 31,120	14 400 31,738	14 380 31,694	14 210 31,319	14 500 31,958	14 510 31,980	14 420 31,782	14 350 31,630	14 260 31,429
203.4 45,704	202.3 45,442	217.3 48,819	196.0 44,029	194.9 43,797	208.8 46,920	206.1 46,313	205.1 46,075	220.4 49,515	180.0 40,441	178.9 40,195	179.2 40,262	178.1 40,018
22 705 50,042	22 878 50,423	22 724 50,084	22 863 50,390	23 036 50,771	22 870 50,405	22 793 50,236	22 966 50,617	22 800 50,251	22 919 50,513	23 011 50,716	23 077 50,862	23 168 51,062

966G Series II Wheel Loader

Operation Specifications

		Quick Coupler Buckets			Waste Buckets	High-Lift Delta*
		Bolt-on edges	Teeth and segments	Teeth	Bolt-on edges	All buckets
Rated capacity	m ³	3.85	3.85	3.65	6.5	
	yd ³	5.0	5.0	4.75	8.5	
Struck capacity	m ³	3.3	3.3	3.1	5.6	
	yd ³	4.3	4.3	4.1	7.28	
Width	mm	3112	3033	3033	3355	
	ft/in	10'2"	9'11"	9'11"	11'0"	
Dump clearance at full lift and 45° discharge	mm	2975	2813	2813	2969	558
	ft/in	9'9"	9'2"	9'2"	9'8"	1'10"
Reach at full lift and 45° discharge	mm	1414	1546	1546	1220	-25
	ft/in	4'7"	5'0"	5'0"	4'0"	-1.0"
Reach with lift arms horizontal and bucket level	mm	2861	3067	3067	2750	404
	ft/in	9'4"	10'0"	10'0"	9'0"	1'3"
Digging depth	mm	139	139	108	154	-25
	in	5.4"	5.4"	4.2"	6.0"	-1.0"
Overall length	mm	9003	9239	9239	8904	544
	ft/in	29'6"	30'3"	30'3"	29'2"	1'9"
Overall height with bucket at full raise	mm	5742	5742	5742	6162	558
	ft/in	18'10"	18'10"	18'10"	20'2"	1'9"
Loader clearance circle with bucket in carry position	mm	14 699	14 765	14 765	14 877	432
	ft/in	48'2"	48'5"	48'5"	48'9"	1'5"
Static tipping load, straight**	kg	16 890	16 810	17 170	18 560	810
	lb	37,226	37,049	37,843	40,906	1785
Static tipping load, articulated at full 37° turn	kg	15 020	14 940	15 280	16 430	550
	lb	33,104	32,928	33,677	36,212	1212
Breakout force***	kN	172.0	172.6	184.1	184.9	-15.6
	lb	38,633	38,770	41,363	41,542	-3505
Operating weight**	kg	22 693	22 810	22 659	23 444	1900
	lb	50,015	50,273	49,940	51,671	4188

* High lift column shows changes in specifications from standard lift to high lift. Add or subtract as indicated to or from specifications given for appropriate bucket to calculate high lift specifications.

** Static tipping load and operating weight shown include sound-suppression cab and ROPS, 26.5 R25 XHA (L-3) steel radial tires, full fuel tank, coolant, lubricants and operator.

*** Measured 102 mm (4.0"): behind tip of cutting edge with bucket hinge pin as pivot point in accordance with SAE J732c.

966G Series II Wheel Loader

Dimensions

All dimensions are approximate.

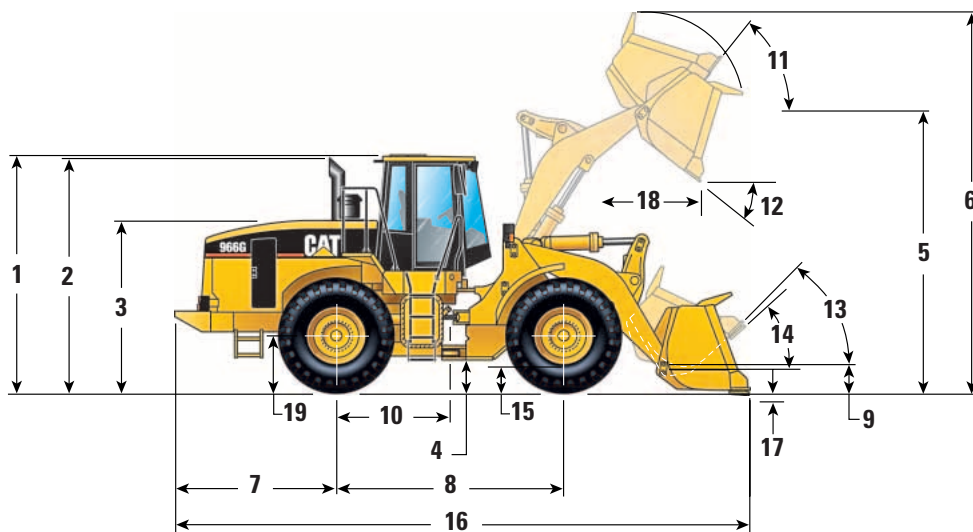

1	Height to top of ROPS	3580 mm	11'9"
2	Height to top of exhaust pipe	3535 mm	11'7"
3	Height to top of hood	2555 mm	8'5"
4	Ground clearance/ Standard tire 26.5 R25 XHA (L-3) See chart below for other tires	565 mm	22"
5	B-Pin height	4225 mm	13'10"
6	Overall height*	Dimensions vary with bucket	
7	Center line of rear axle to edge of counterweight	2460 mm	8'1"
8	Wheelbase	3450 mm	11'4"
9	B-Pin height @ carry	485 mm	19"
10	Center line of rear axle to hitch	1725 mm	5'8"

11	Rack back @ maximum lift	61°
12	Dump angle @ maximum lift (GP bucket)	50°**
13	Rack back @ carry	47°
14	Rack back @ ground	42°
15	Axle Housing Clearance	430 mm 1'5"
16	Overall Length*	Dimensions vary with bucket
17	Digging Depth*	Dimensions vary with bucket
18	Reach*	Dimensions vary with bucket
19	Height to center line of axle	795 mm 2'7"

*Refer to Operation Specifications chart.

**MH bucket is 45°.

Tires

Tread width for all tires is 2230 mm (7'4")

	Width over tires		Change in vertical dimensions		Change in operating weight		Change in static tipping load – straight	
	mm	inches	mm	inches	kg	lb	kg	lb
26.5-25 20PR (L-2)	2965	117	-80	-3.2	-469	-1030	-349	-770
26.5-25 20PR (L-3)	3035	119	-25	-1.0	-224	-490	-168	-370
26.5 R25 XHA 1 (L-3) standard	2965	117	—	—	—	—	—	—
26.5 R25 GP-2B 1 (L-3)	3000	118	-30	-1.2	-49	-100	-36	-80
26.5 R25 MX (L-5)	3000	118	+63	+2.5	+1012	+2230	+732	+1314

NOTE:

Tire options include tires and rims.

In certain applications (such as load-and-carry work) the loader's productive capabilities might exceed the tires' tonnes-km/h (ton-mph) capabilities. Caterpillar recommends consulting a tire supplier to evaluate all conditions before selecting a tire model.