



3508 B Industrial Engine

820 bkW/1100 bhp @ 1800 rpm

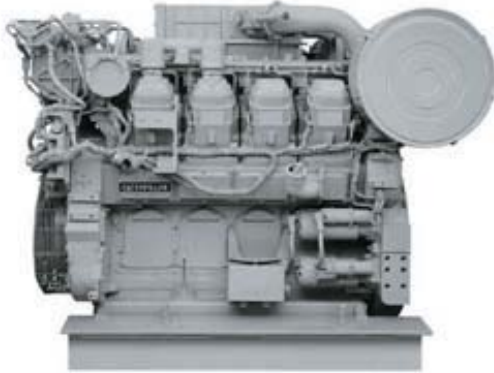

Image shown may not reflect actual engine

CAT® ENGINE SPECIFICATIONS

V-8, 4-Stroke-Cycle Diesel

Bore.....	170.0 mm (6.69 in)
Stroke.....	190.0 mm (7.48 in)
Displacement.....	34.53 L (2,107.15 in ³)
Aspiration.....	Turbocharged / SCAC
Compression Ratio.....	14.0:1
Rotation (from flywheel end).....	Counterclockwise
Capacity for Liquids	
Cooling System.....	102.7 L (27.1 gal)
Lube Oil System (refill).....	102.0 L (26.9 gal)
Engine Weight, Net Dry (approximate).....	4,271 kg (9,416 lb)

FEATURES

EMISSIONS

Meets Tier 1 emission requirements. Tier 1 refers to EPA (U.S.) non-road standards.

SINGLE SOURCE SUPPLIER

Caterpillar:

- Casts engine blocks, heads, cylinder liners, and flywheel housings
- Assembles complete engine

Ownership of these manufacturing processes enables Caterpillar to produce high quality, dependable product.

Factory-designed systems built at Caterpillar ISO 9001:2000 certified facilities

TESTING

Prototype testing on every model:

- proves computer design
- verifies system torsional stability
- functionality tests every model

Every Caterpillar engine is dynamometer tested under full load to ensure proper engine performance

FULL RANGE OF ATTACHMENTS

Wide range of bolt-on system expansion attachments, factory designed and tested

UNMATCHED PRODUCT SUPPORT OFFERED THROUGH WORLDWIDE CATERPILLAR DEALER NETWORK

More than 1,500 dealer outlets.

Caterpillar factory-trained dealer technicians service every aspect of your industrial engine.

99.7% of parts orders filled within 24 hours worldwide.

Caterpillar parts and labor warranty

Preventive maintenance agreements available for repair before failure options.

Scheduled Oil Sampling program matches your oil sample against Caterpillar set standards to determine:

- internal engine component condition
- presence of unwanted fluids
- presence of combustion by-products

WEB SITE

For all your industrial power requirements, visit www.cat-industrial.com.



STANDARD ENGINE EQUIPMENT

820 bkW/1100 bhp @ 1800 rpm

Air Inlet System

Separate circuit aftercooler core, corrosion resistant coated (air side), air cleaner (dual element with service indicator), Dual rear mounted turbochargers

Control System

Caterpillar ADEM™ II Electronic Engine Control, RH, with electronic unit injector fuel system (10 amp DC power required to drive electronic engine control module)

Cooling System

Thermostats and housing, Jacket water pump, gear driven, centrifugal, Connections for radiator cooling

Exhaust System

Exhaust manifold, dry,
Dual turbochargers with watercooled bearings,
Exhaust outlet 203 mm (8 in) round flange

Flywheels & Flywheel Housings

Flywheel, SAE No. 0, 151 teeth, Flywheel housing, SAE No. 0, SAE standard rotation

Fuel System

Fuel filter, LH spin-on type,
Fuel transfer pump,
Electronically controlled unit injectors

Instrumentation

No standard instrumentation, Optional, remote instrumentation available

Lube System

Crankcase breather, top mounted.
Oil cooler, Oil filler and dipstick, RH.
Oil pump, Oil filter, LH, spin-on type.
Front sump oil pan, 250 hour change interval.

Mounting System

Trunnion front support

Power Take-Offs

Accessory drive, lower LH, Front housing, two sided

Protection System

ADEM™ II monitoring system to provide customer programmable engine.
De-rate strategies to protect against adverse operating condition.
Emergency stop logic inputs provided at 40-pin customer interface connection.

General

Paint, Caterpillar Yellow,
Vibration damper and guard,
Lifting eyes

Note

These engines are not configured properly for application in hydraulic excavators or front shovels. To obtain proper rating and configuration for excavators and shovels, please contact your Area/District Industrial Sales Representative or the 3500 Product Group.



PERFORMANCE CURVES

820 bkW/1100 bhp @ 1800 rpm

IND - C (Intermittent) - DM4636-01

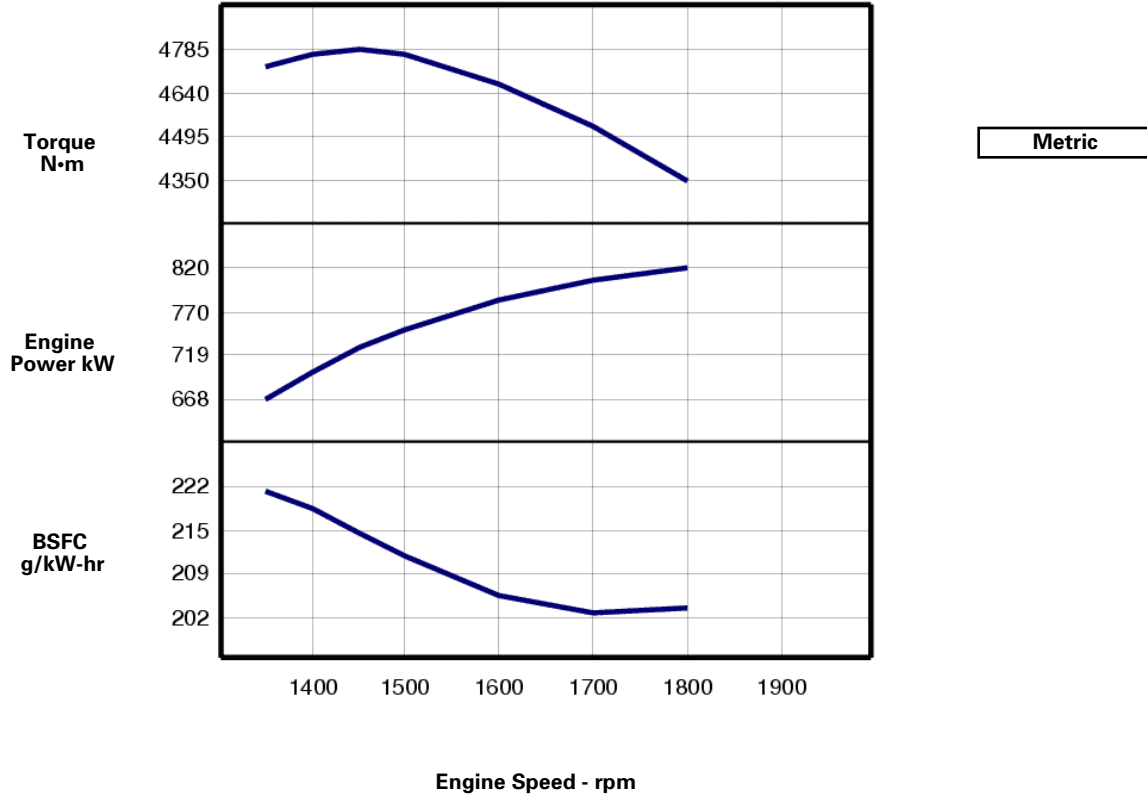

Engine Speed rpm	Engine Power kW	Torque N·m	BSFC g/kW-hr	Fuel Rate L/hr
1800	820	4350	203.2	198.6
1700	806	4528	202.5	194.6
1600	783	4670	205.2	191.4
1500	749	4769	211.2	188.5
1450	727	4785	215	186.2
1400	699	4767	218.7	182.2
1350	669	4729	221.6	176.6



PERFORMANCE CURVES

820 bkW/1100 bhp @ 1800 rpm

IND - C (Intermittent) - DM4636-01

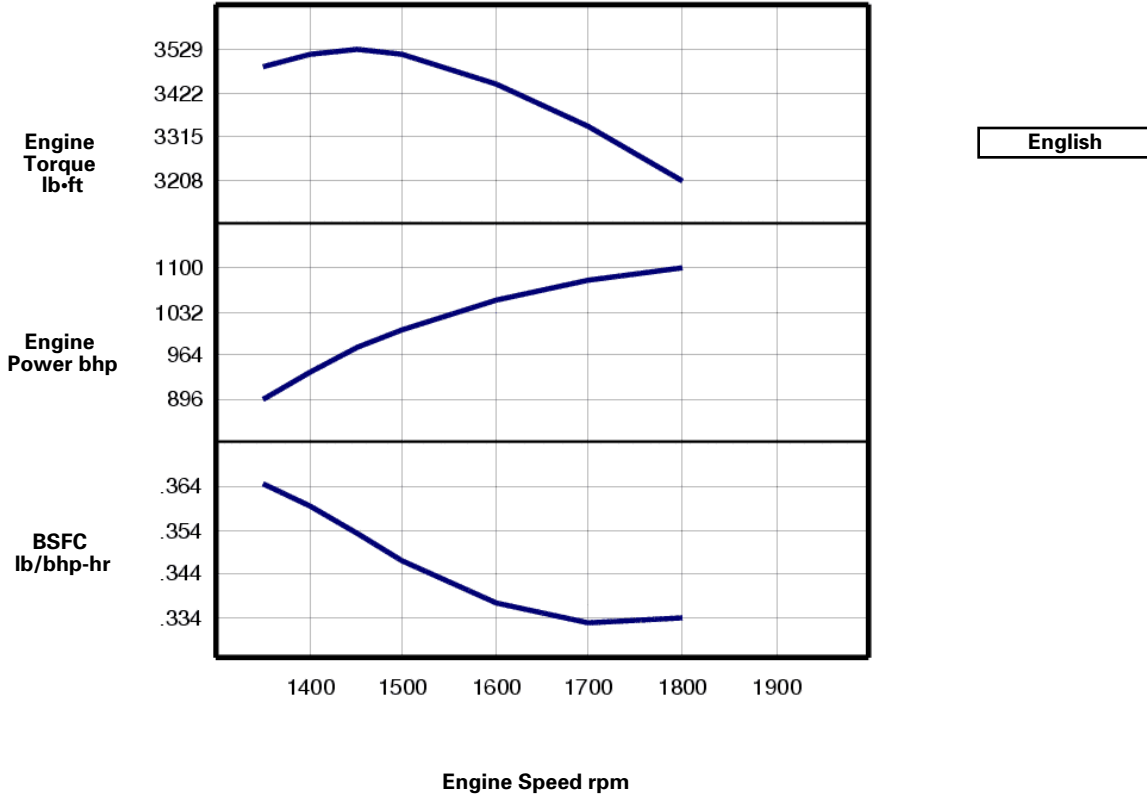

Engine Speed rpm	Engine Power bhp	Engine Torque lb-ft	BSFC lb/bhp-hr	Fuel Rate gal/hr
1800	1100	3208	.334	52.5
1700	1081	3340	.333	51.4
1600	1049	3444	.337	50.6
1500	1004	3517	.347	49.8
1450	974	3529	.353	49.2
1400	937	3516	.360	48.1
1350	896	3488	.364	46.7



RATINGS AND CONDITIONS

820 bkW/1100 bhp @ 1800 rpm

IND - C (Intermittent) Intermittent service where maximum power and/or speed are cyclic. The power and speed capability of the engine can be utilized for one uninterrupted hour followed by one hour of operation at or below IND - A. Time at full load is not to exceed 50% of the duty cycle. Typical service examples are: agricultural tractors, harvesters and combines, off highway trucks, fire pump application power, blast hole drills, rock crushers and wood chippers with high torque rise, and oil field hosting.

Engine Performance Engine performance is corrected to inlet air standard conditions of 99 KPA (29.31 IN HG) dry barometer and 25 deg C (77 deg F) temperature. These values correspond to the standard atmospheric pressure and temperature as shown in SAE J1995.

Performance measured using a standard fuel with fuel gravity of 35 degrees API having a lower heating value of 42,780 KJ/KG (18,390 BTU/LB) when used at 29 DEG (84.2 DEG F) where the density is 838.9 G/L (7.001 LB/US GAL).

The corrected performance values shown for Caterpillar engines will approximate the values obtained when the observed performance data is corrected to SAE J1995, ISO 3046-2 and 8665 and 2288 and 9249 and 1585, EEC 80/1269 and DIN 70020 standard reference conditions.

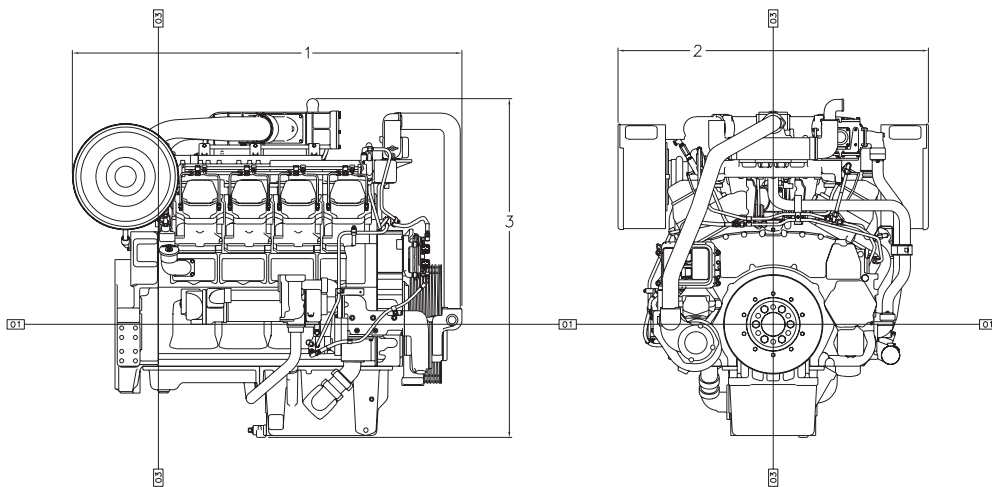

Engine Dimensions	
(1) Length	2136.5 mm (84.11 in)
(2) Width	1703.0 mm (67.05 in)
(3) Height	1858.4 mm (73.17 in)

Note: Do not use for installation design. See general dimension drawings for detail (Drawing # 2002730).

Performance Number: DM4636-01

Feature Code: 508DO02 Arr. Number: 1918408

Materials and specifications are subject to change without notice.

16285231

© 2012 Caterpillar

All rights reserved.

The International System of Units (SI) is used in this publication.

CAT, CATERPILLAR, their respective logos, "Caterpillar Yellow," the "Power Edge" trade dress, as well as corporate and product identity used herein, are trademarks of Caterpillar and may not be used without permission.